



AWEA MECHANTRONIC CO.,LTD.

Company Presentation

BY JASON HSU

Spoke man

2017/03/16

ISO 9001



ISO 14001



Presentation Outline

- **Market**
- **AWEA Group**
- **Products**
- **Operating Performance**
- **Current market situation & Competitive strategy**

What is Machine Tool ?

- ❑ Machine Tool is the machine to produce the parts of a machine. It has high quality of technology, and reflects the industry capability, such as **Japan, German, US** and **Italy**.
- ❑ Most of the parts and the moulds of the plastic, quartz and electronic components need machine tools to do machining. It is a big market and not easy to be replaced. ◦

Main applications

- Automobile component molds 30%
- Hi-precision parts 30%
- Aerospace components machining 10%~20%
- 3C industry 10%
- Others 10%



The Types of Machine Tools

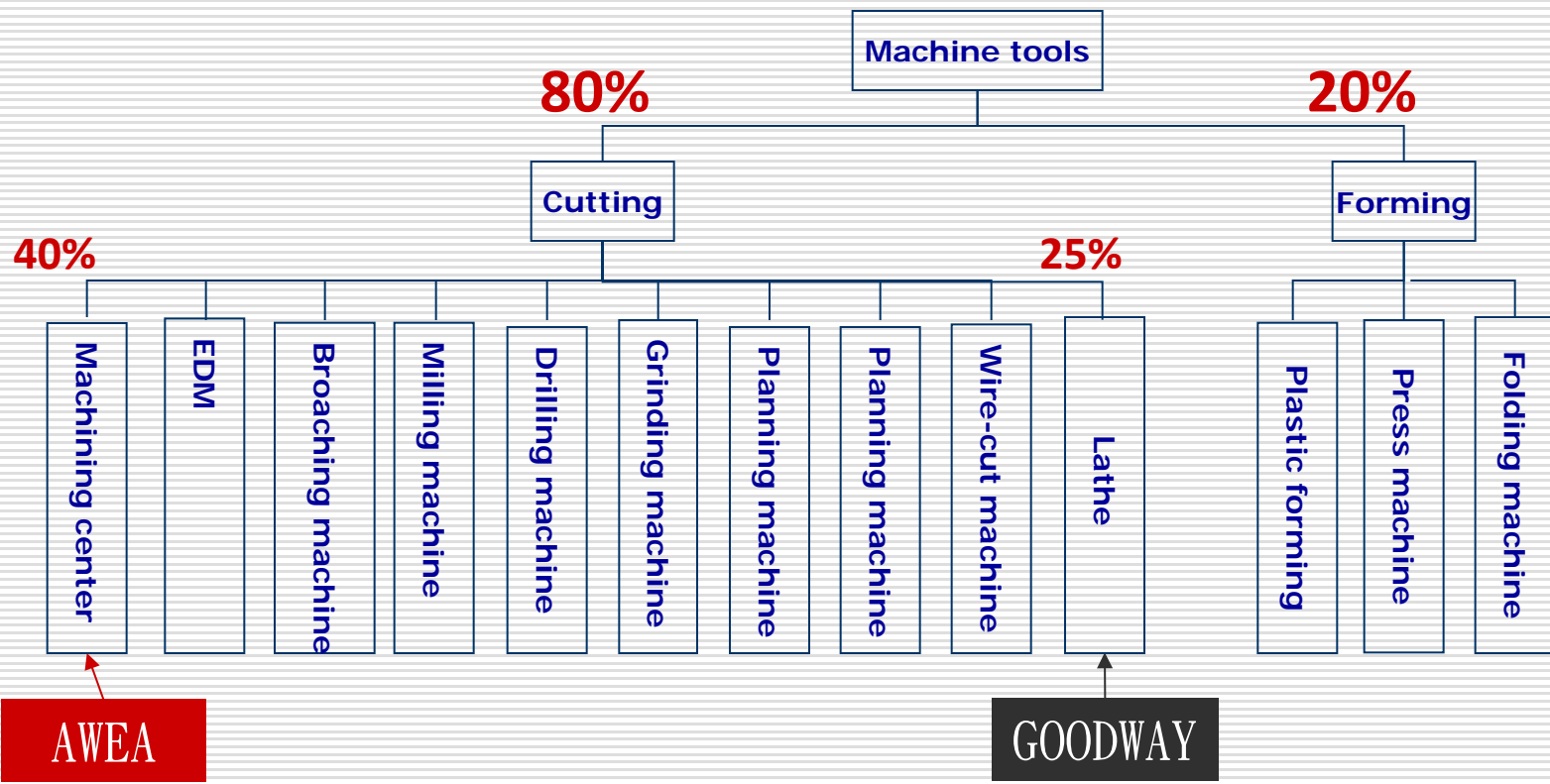

AWEA

EXTRON

GOODWAY

Importance of Machine Tools

Crank Shaft
Turning Center



Cylinder
Machining Center

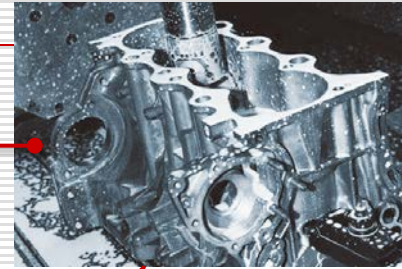

Aluminum Wheel
Wheel Turning Center



Bumper Mold
Bridge Type
Machining Center



Wheel Mold
Vertical Turning
Center



Brake Disk
Vertical Turning
Center

Importance of Machine Tools



Hub

Horizontal Boring Mills

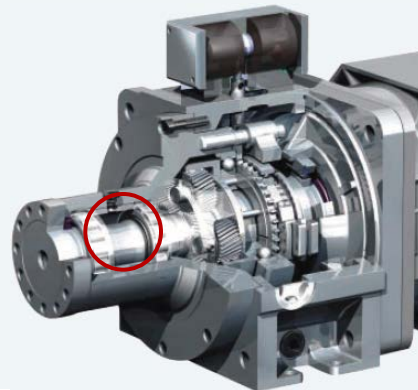

Precision Parts

Turning Center

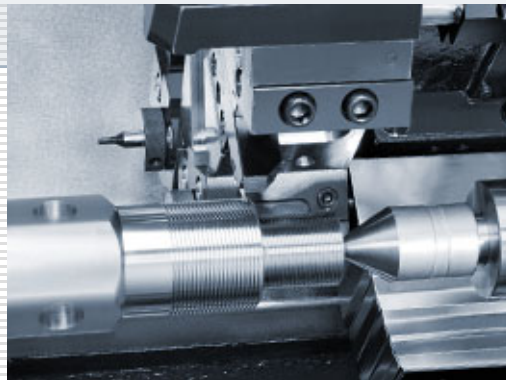

Turbo-propeller

5-axis Turning Center

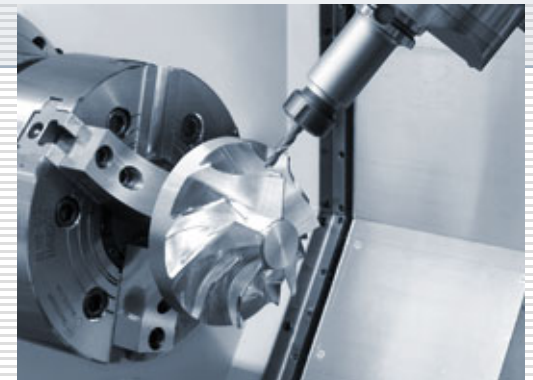

Company Profiles

Group Members



GOODWAY MACHINE CORP.(Taiwan&China)
CNC Turning Center Manufacturing / Since 1975



AWEA MECHANTRONIC CO.,LTD. .(Taiwan&China)
CNC Machining Center Manufacturing / Since 1986



YAMA SEIKI USA., INC.(America)
Sales of Turning Centers & Machining Centers / Since 2000



YIH CHUAN MACHINERY INC.
 CNC Machining Center Manufacturing / Since 1972

Operating Centers – Taiwan



GOODWAY Headquarters /
18,600 m²



AWEA Headquarters /
26,000 m²



GOODWAY CTSP Branch /
26,600 m²



AWEA CTSP Branch /
26,600 m²



EXTRON Headquarters /
10,400 m²



GOODWAY GROUP Chiayi Branch
100,000 m²

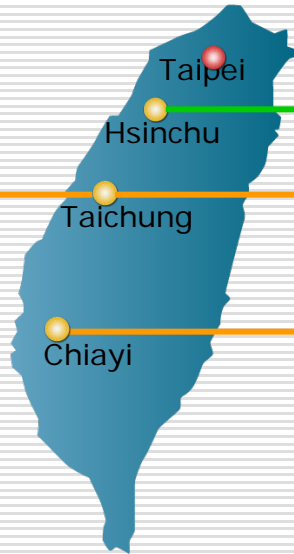

Operating Centers – CHINA



GOODWAY GROUP (WUJIANG)
66,800 m²



GOODWAY GROUP (DONGGUAN)
500 m²



AWEA (SHANGHAI) /
8,600 m²

Global Sales Network

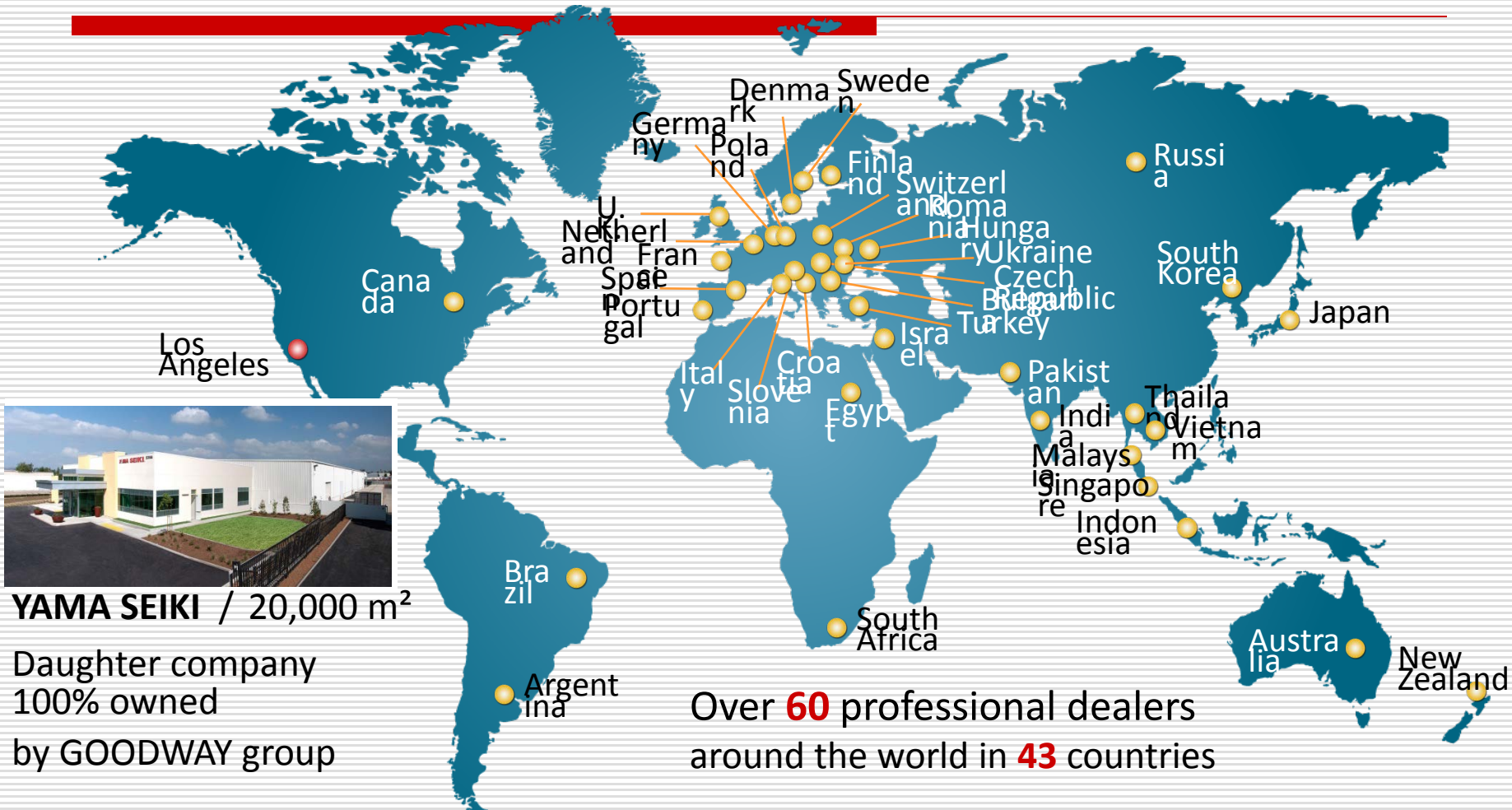

YAMA SEIKI / 20,000 m²

Daughter company
100% owned
by GOODWAY group

Over **60** professional dealers
around the world in **43** countries

Company Profiles

- ❑ **1986 AWEA was founded in Hsin-Chu, Taiwan.**
- ❑ **1998 Entered the OTC market.**
- ❑ **2000 Became the listed company in TSEC.**

End of 2017/02

- ❑ **Capital: NT\$965m (USD\$31m)**
- ❑ **Employees: 497 (Hsin-Chu factory: 218, Tai-Chung factory: 264)**
- ❑ **RD members: 65**
- ❑ **Major products: C type and bridge type CNC machine center**
- ❑ **Subsidiaries : Best Way Shang-Hai , Dawea Su-Zhou, Wu-jiang Su-Zhou (all 100% holding), EXTRON (60% holding)**

Certification

- ❑ **ISO 9001 Quality System --Germany TUV CERT**
- ❑ **ISO 14001 Environmental System --Germany TUV CERT**
- ❑ **CE European Safety System --UK AMTRI**

Investment

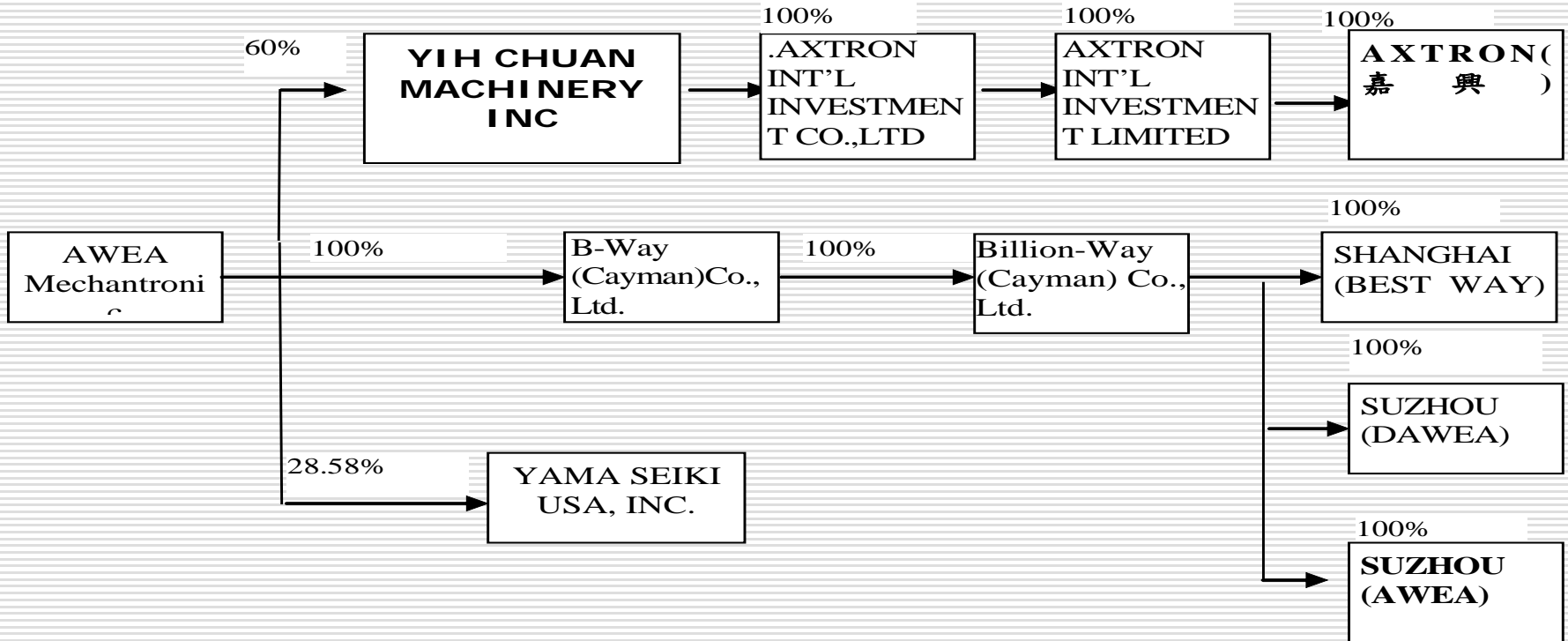

Products

Market position strategy-global view

Targeting medium-class: good market size with healthy margin

Controller Marker
FANUC
Heidenhain
Mitsubishi
SIEMENS
PC BASE

Machine tool makers

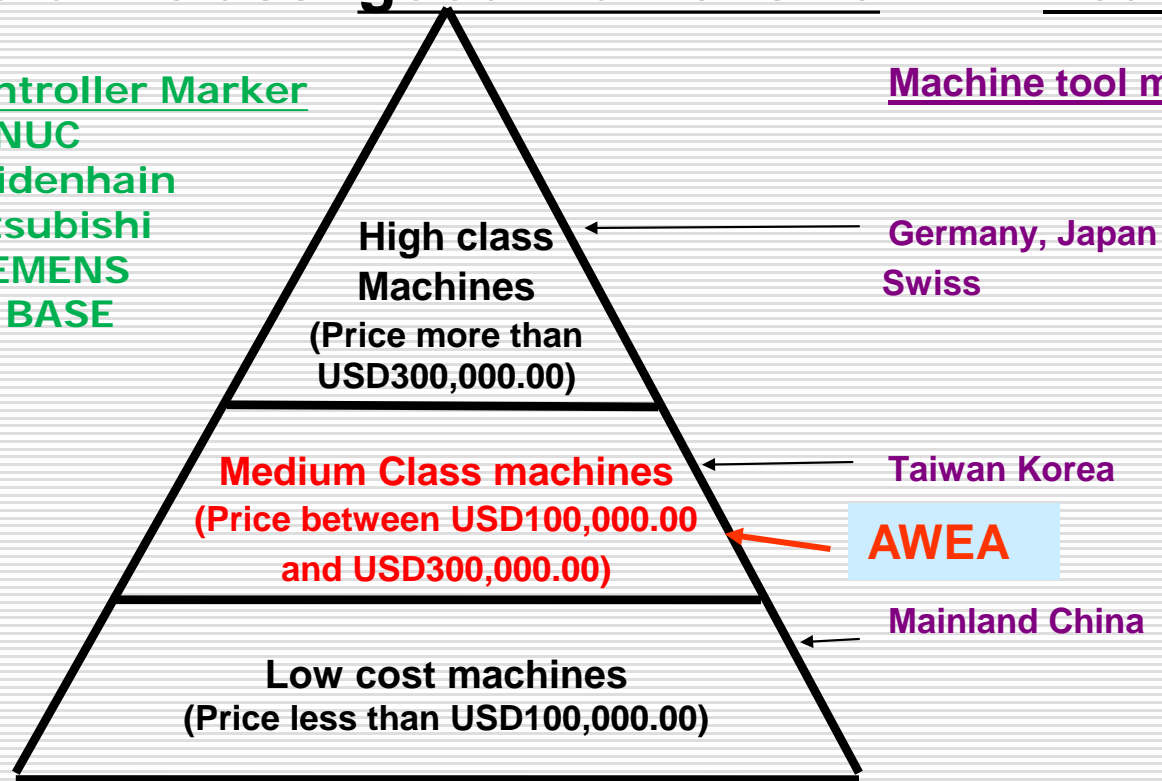

Main Products

□ 5-axis Machining Center Series

- Work-piece side rotation / Tooling side rotation

□ 5-face Machining Center Series

- Moving cross-rail / Multi-storage automatic head changer /
High efficiency automatic head changer

□ Bridge Type Machining Center Series

- X: 1,600 ~ 20,000 mm / Y: 1,200 ~ 7,000 mm / Z: 760 ~ 1,400 mm

□ Horizontal Boring Mills Series

- X: 1,500 ~ 4,000 mm / Y: 1,200 ~ 2,400 mm / Z: 900 ~ 1,700 mm

□ Vertical Machining Center Series

- X: 510 ~ 2,500 mm / Y: 400 ~ 1,000 mm / Z: 330 ~ 1,000 mm

Feature Models of AWEA



MB-APC Series

High Precision Boring Mills
w/ Auto Pallet Changers



MCP16054

X-axis Travel : 16,000 mm
Y-axis Travel : 5,200 mm



AH Series

Ultra Performance
Horizontal Machining
Centers



BM/AF-APC Series

VMC w/ High Efficiency
Auto Pallet Changers



MVP Series

Moving Cross-Rail
Multi-storage AHC

Feature Models of AWEA



FV-960

5-Axis Vertical Machining Center



FCV-620

Ultra Performance 5-Axis
Machining Center



FCV-800

Gantry Type 5-Axis Machining
Center



MEGA5 Series

A / C axes milling head
5 axes Simultaneous
Machining

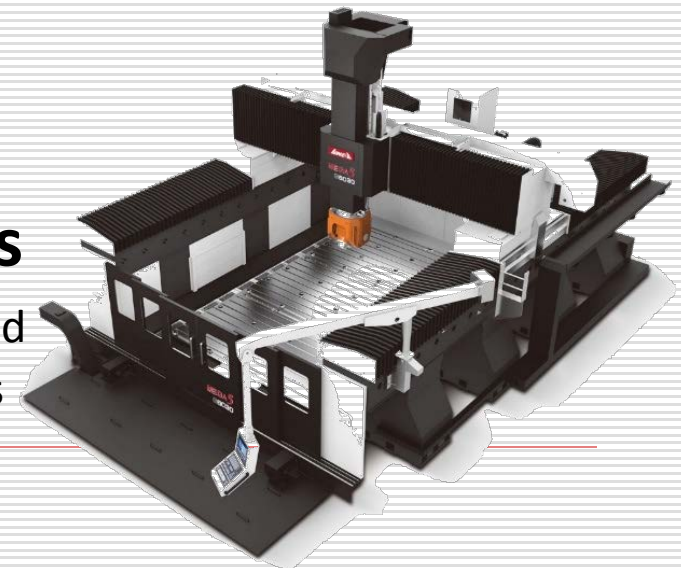

Operating Performance

Financial results



Revenue, cost, net income and EPS

Unit:NT/Thousand

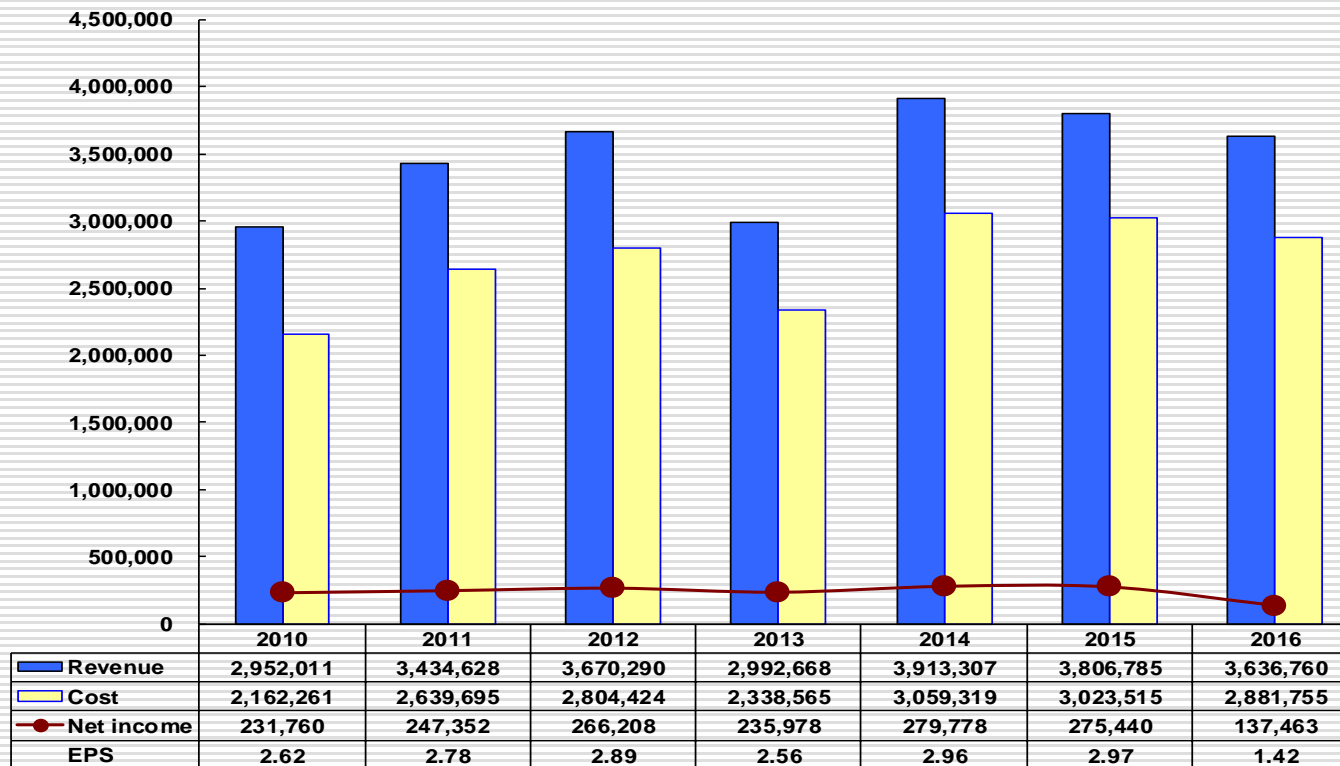

Financial results--Dividends

| year | 2012 | 2013 | 2014 | 2015 | 2016(F) |
|--------------|------|------|------|------|---------|
| stocks | - | - | - | 0.5 | |
| Cash | 1.5 | 2.0 | 2.2 | 0.5 | 0.7 |
| TOTAL | 1.5 | 2.0 | 2.2 | 1.0 | 0.7 |

Marketing Share

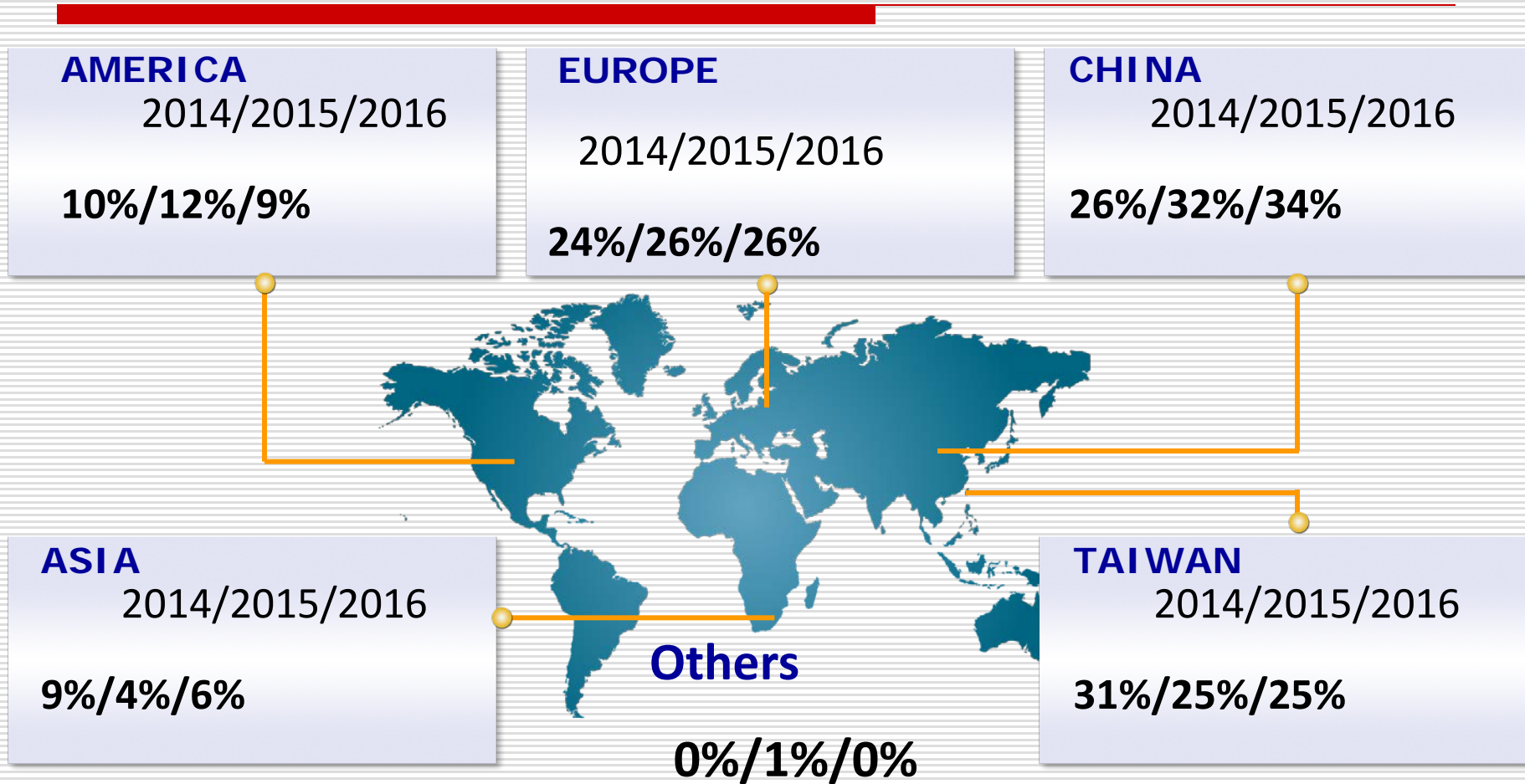

Market & Competitive strategy

Current market situation

- ❑ Currency exchange rate fluctuation creates new challenges.
- ❑ Demand for automobile industry remains.
- ❑ Central banks are raising the interest rate, market have signs of warming up around the world.
- ❑ Aerospace parts manufacturing localization creates new opportunities.
- ❑ Government policy for intelligent machines and indigenous naval ship building creates new requirements.
- ❑ Raw materials cost raising.

Operating risk

- ❑ Goodway group already grows to a scale competing with international major players.
- ❑ Government support is limited. No international agreement on tax deduction. Having a unfavorable stance competing with major export countries.
- ❑ Currency exchange rate fluctuation is too big. NT\$ recent appreciation is not helpful for export market.
- ❑ Competition from domestic makers using low price strategy is harmful for the industry long term development.

Competitive strategy

- ❑ Comprehensive product range.
- ❑ Well established global sales network.
- ❑ Accommodated production bases (Taiwan-High production efficiency : China-Big market potential, has regional tax deduction agreement and export subsidies)
- ❑ Continuous new product development and RD investment.
- ❑ Group resources support.
- ❑ Long term production base expansion for future development requirements.

Thank you
&
Q & A