



**Jamna Auto Industries Ltd.**

**March 3, 2017**

**National Stock Exchange of India Limited**  
Exchange Plaza,  
Bandra Kurla Complex,  
Bandra East,  
Mumbai – 400 051

**Company's Listing Code: JAMNAAUTO**

**Subject: Presentation on financial results**

Dear Sir/Madam,

Pursuant to Clause 30 (2) read with Schedule III Part A of the Securities and Exchange Board of India (Listing Obligations and Disclosure Requirements) Regulations, 2015 please find attached herewith Presentation on financial results for Q3 FY 2016-17.

This is for your information and record.

Thanking you

Yours faithfully,

**For Jamna Auto Industries Limited**

**Praveen Lakhera**  
**Company Secretary & Head-Legal**

# Jamna Auto Industries Limited

Company Profile

2016-17

# Jamna Auto Industries Limited

Sales

**FY 2015-16 = INR 1,256 crores (~ US\$187Mn)**

Q-3 2016-17 = INR 306 Crores (~ US\$ 45 Mn)

\$= INR 67.1

Market  
Capitalization

**INR 1,600 crores (~ US\$ 238 Mn)**

(Share Price INR 200.75 /- as on 10.02.2017)

Production  
Spring Capacity

Existing : 180,000 MT p.a.

*Among World's Top 3*

Alliance

**Ridewell (USA) – Air Suspension & Lift Axle**

Plants

**8 Plants in 6 States**

Listed on Stock  
Exchange

**BSE – 520051**

**NSE – JAMNAAUTO**

## Global Spring Manufacturers

## Global Leaf Market Scale

### Indian Market Scenario

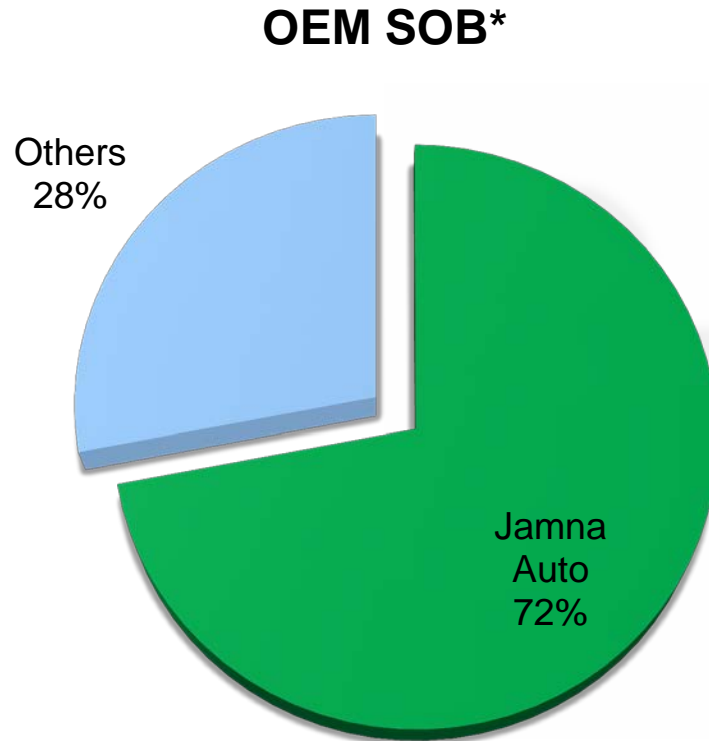

Note-The data as shown above is for Q3- 2016-17 in tonnage

\* SOB-Share of business

Data Source- Internal

### 1980's

Leaf Spring Manufacturer	Base Country	Capacity
NHK Springs Co. Ltd.	Japan	200,000
Delphi	USA	100,000
Eaton/Oxford	Canada	100,000
Krupp	Germany	40,000
Hendrickson	USA	40,000
DSP	USA	40,000
Rejna	Europe	40,000
Hoesh	Germany	30,000
Sarfedern	Germany	20,000
Johns Woodhead	UK	10,000

### Current

Leaf Spring Manufacturer	Base Country	Capacity
Rassini	Mexico	250,000
Hendrickson	Canada & Mexico	190,000
<b>Jamna Auto Industries Ltd.</b>	<b>India</b>	<b>180,000</b>
NHK Springs Co. Ltd.	Japan & Thailand	150,000
Ventanna	Europe	110,000
Dong Feng	China	105,000
FAW	China	100,000
MBHA	Spain	36,000
Olgin	Turkey	28,000
LPDN	Europe	24,000

Capacity in Tons per Annum

# Shareholding Pattern

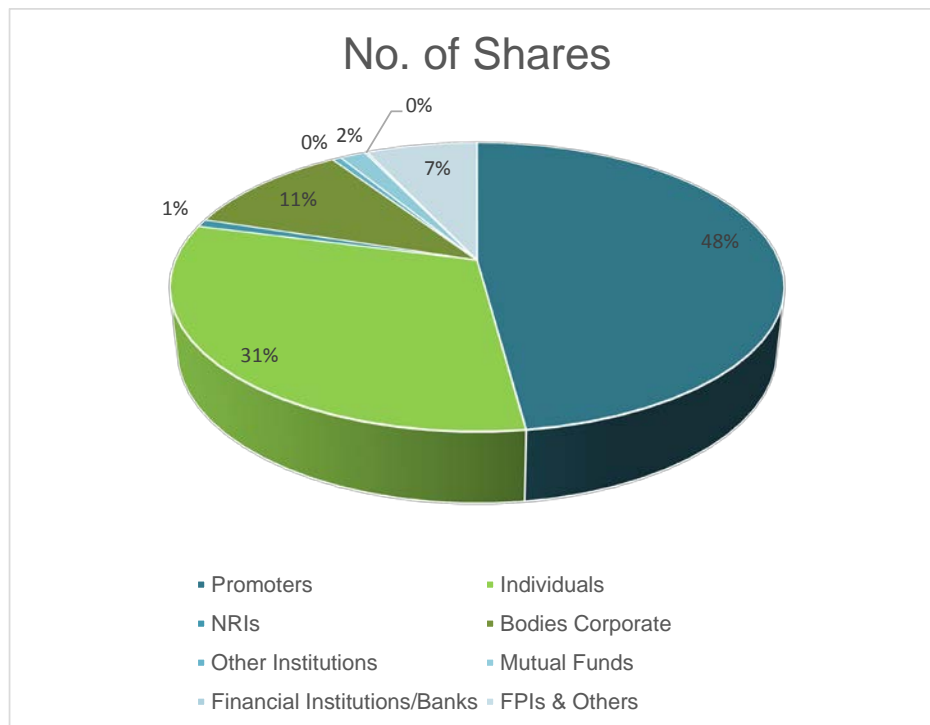

Category	No of shares	In %
Promoters	38,154,630	47.88
Individuals	24,862,115	31.20
NRIs	681,612	0.86
Bodies Corporate	8,548,593	10.73
Other Institutions	440,193	0.55
Mutual Funds	1,291,684	1.62
Financial Institutions/Banks	129,445	0.16
FPIs & Others	5,574,504	7.00
<b>Total</b>	<b>79,682,776</b>	<b>100.00</b>

Note- The Shareholding Pattern shown above is as on December 31, 2016

# Our Strengths

**62 Years in Manufacturing Business in India**

**Manufacturing around 480 Parts for OEMs & over 2000 parts for After Market**

**Industry Leader in India - nearest competitor with little Market Share**

**OEM Market Share 72% (Qtr--3 weighted average)**

**Footprints across all geographical locations in India**

**Only company with Spring R&D Centre in India**

# Products

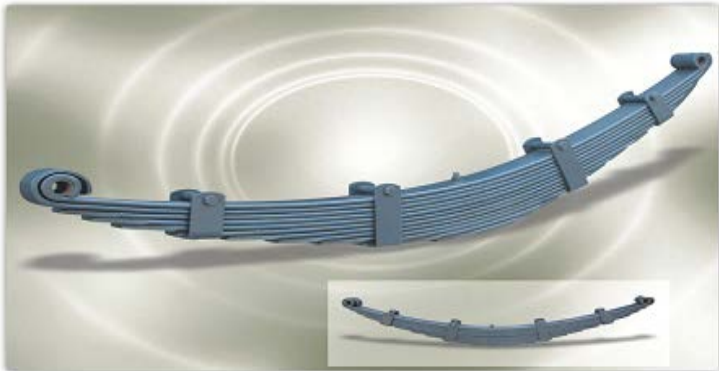

Conventional Leaf spring

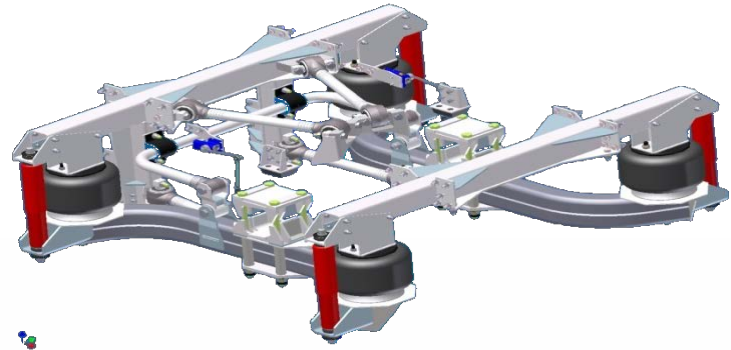

Air Suspension

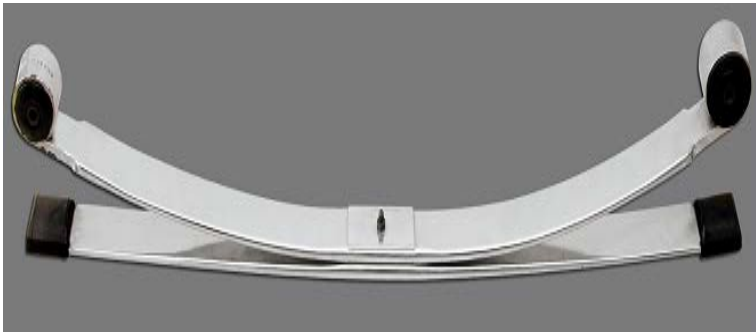

Parabolic Leaf Spring



Lift Axle

# Presence

## Locations

### Main Plants

- Yamuna Nagar
- Malanpur
- Chennai:
  - Maraimalai Nagar (Leaf Spring)
  - Pillaipakkam (Lift Axle)
- Jamshedpur
- Pune (Plant & R&D Centre)
- Hosur (starting soon)

### Assembly Plants

- Pant Nagar

**8 Locations**

## Products

- Leaf Spring
- Parabolic Spring
- Lift Axle
- Air Suspension

**4 Products**

## Markets

- OE India
- AM India
- OE – Exports
- AM – Exports

**4 Markets**

\* OE India- Original Equipment Manufacturer  
\* AM India – After Market India



**Serving more than 20 OEM Customer Locations in India**



# Customers



## JAI & OEMs Presence in India

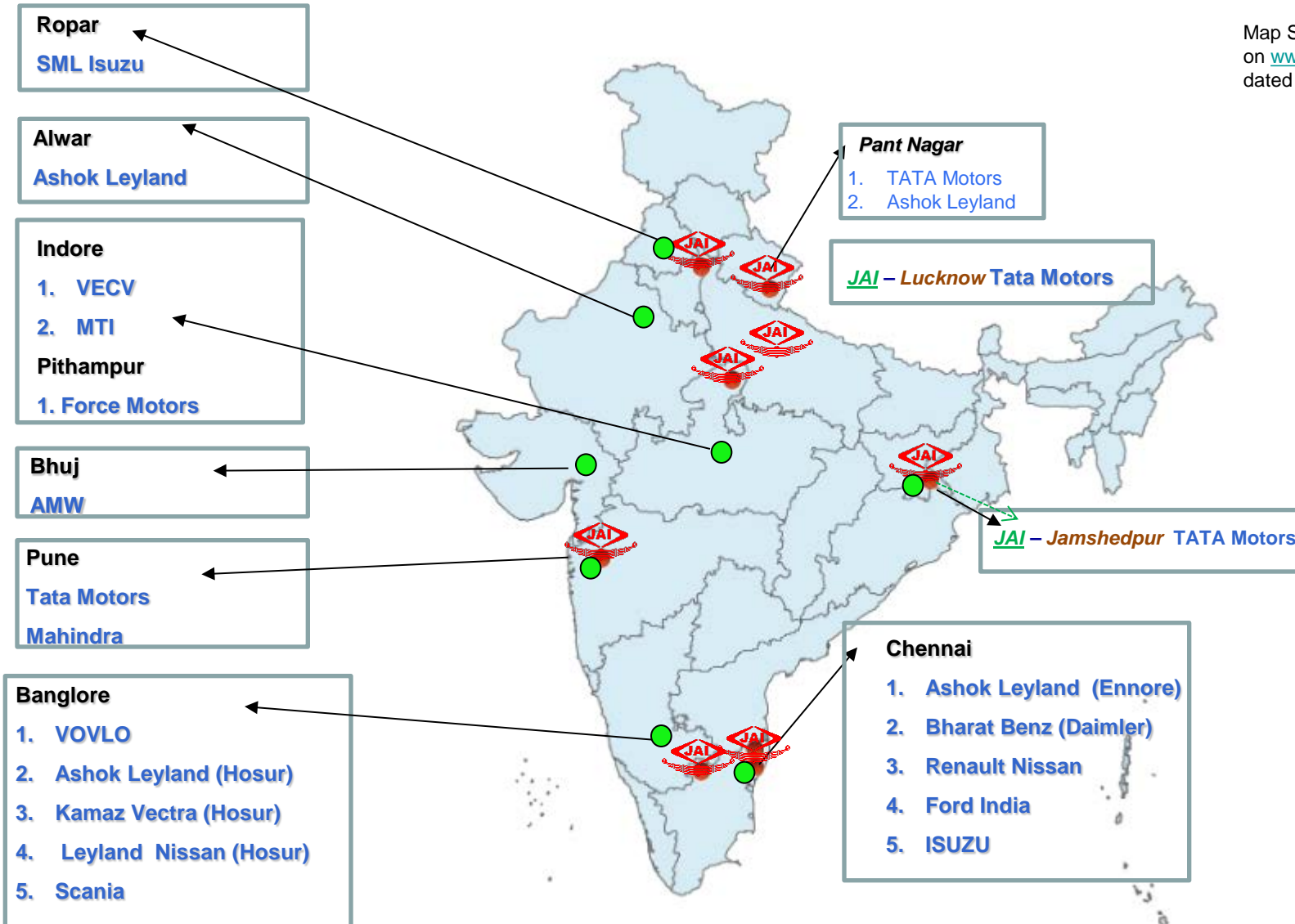

# Project Lakshya

## Jai's medium term strategy focused on value creation

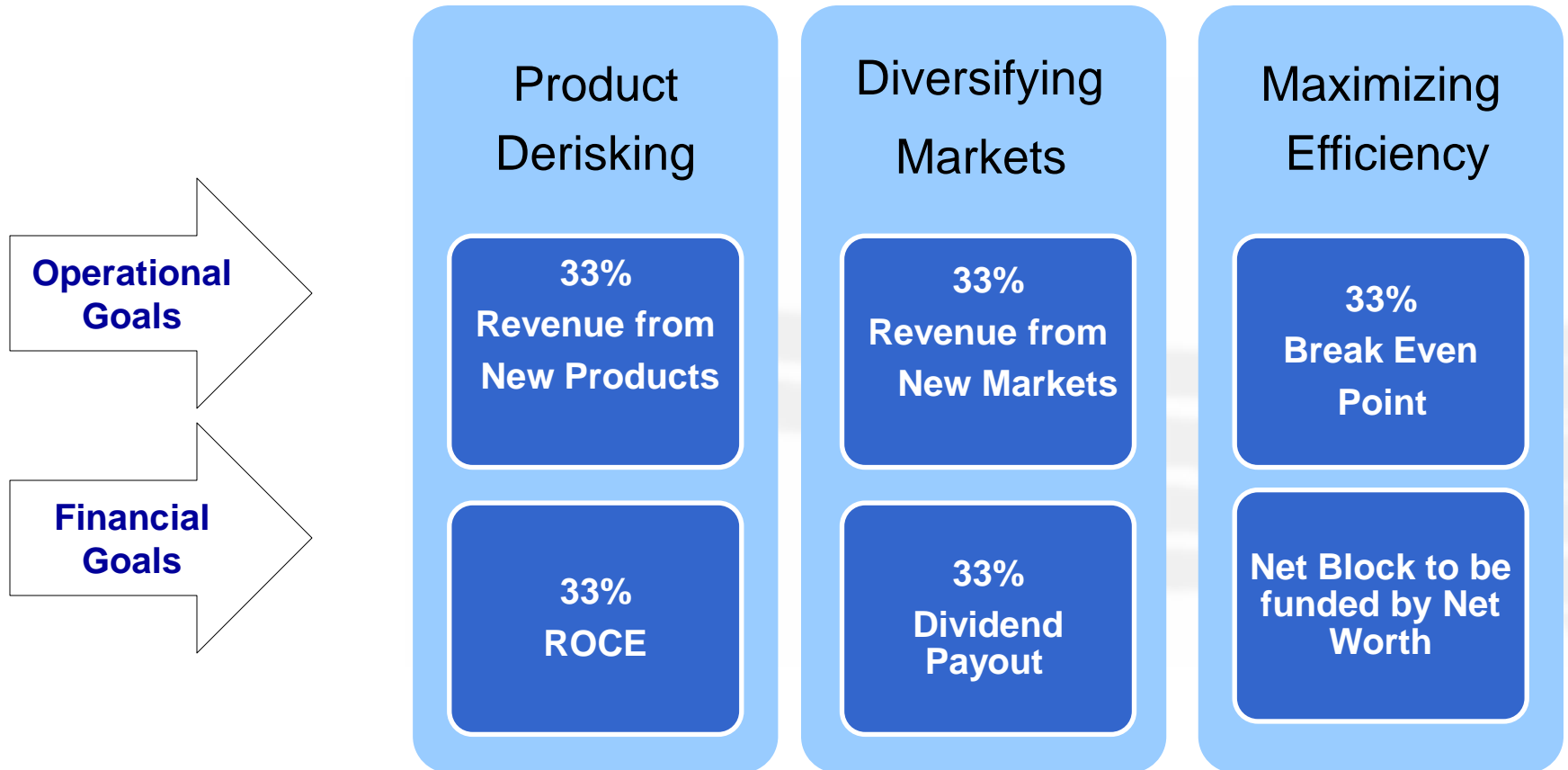

# Jamna Auto Industries Ltd



Q3 Update

2016-17

# Financial Results – Q3 FY'17

	<i>INR in Cr</i>				
	2015-16	2015-16	2016-17	2016-17	Growth*
	12m	Q3	Q3	Q2	in %
Net Sales	1,255.8	281.6	305.7	275.3	9%
Export Sales	10.8	2.5	1.7	1.7	-31%
EBITDA	164.9	38.5	43.8	40.4	14%
Operating Margin	119.7	25.8	34.3	29.2	33%
PBT	105.0	22.1	32.4	26.9	47%
PAT	71.5	15.5	20.9	21.0	35%
Cash Accruals	116.7	28.2	30.4	32.2	8%
<hr/>					
EBITDA Margin (%)	13.1%	13.7%	14.3%	14.7%	5%
Operating Margin (%)	9.5%	9.2%	11.2%	10.6%	22%
PBT (%)	8.4%	7.8%	10.6%	9.8%	35%
PAT (%)	5.7%	5.5%	6.8%	7.6%	24%
Cash Accruals	9.3%	10.0%	9.9%	11.7%	-1%

Cash Accruals= PAT + Depreciation

\*Growth vis-à-vis Q3 2015-16,  
Note: EBITDA includes Other  
Income

# Financial Highlights – Q3 FY'17

---

- **Sales** Increased by **9%** (*vis-à-vis* Q3 2015-16)
- **SOB** Increased by **2%** (*vis-à-vis* Q3 2015-16)
- **EBIDTA** **14.3%** in the quarter
- **ROCE** Improved ROCE to **42%** -maintaining LAKSHAY target
- **NW=NB** Capital expenditure met out of **internal** cash generation

# Financial Highlights – Q3 FY'17

---

## ❑ Credit Ratings by ICRA:

- Short Term Rating **A1+**
- Commercial Paper Rating **A1+**
- Long Term Rating **AA-**

## ❑ Borrowing:

- **'Virtually debt free'** (except working capital funding)
- **Strong liquidity position** with over INR 400 cr. working capital limits.  
(Utilization against the same as on 31.12.16 < INR 150 cr.)

# CV Industry & JAI's Journey

Particulars	Q3 2015-16	Q3 2016-17	% Growth
OEMs - Total Commercial Vehicle Prod. (Nos)	189,255	190,826	1%
OEMs - H & MCVs Prod. (Nos.)	77,836	80,067	3%
OEMs - LCVs Prod. (Nos.)	111,419	110,759	-1%
JAI's Net Sale (INR in Crore)	282	306	9%
JAI's Market Share (%)	66	72	9%

Vehicle Production information source : **SIAM** (i.e adjusted for Daimler India Commercial Vehicles Ltd-DICV)

---

## FORWARD LOOKING STATEMENT :

This presentation is made to enable investors to comprehend our prospects and take informed investment decisions. This presentation may contain certain forward looking statements within the meaning of applicable laws and regulations. We cannot guarantee that these forward-looking statements will be realized, although we believe we have been prudent in assumptions. The achievement of results is subject to risks, uncertainties and even inaccurate assumptions. Should known or unknown risks or uncertainties materialize, or should underlying assumptions prove inaccurate, actual results could vary materially from those anticipated, estimated or projected. Readers should bear this in mind. We undertake no obligation to publicly update any forward-looking statements, whether as a result of new information, future events or otherwise.



**Thank You**