

XTEK Limited

Annual General Meeting

CEO's Address – Brian Malcolm

24 November 2011

XTEK Limited – Annual General Meeting

Aim

To update XTEK shareholders on Company strategic developments and current operational focus

XTEK Limited – Annual General Meeting

Scope

- **Strategic Context**
- **Strategic Development**
- **Operational Focus**
- **Operational Objectives**
- **Conclusion**
- **Questions**

XTEK Limited – Annual General Meeting

Strategic Context

EXECUTIVE VISION:

A rejuvenated, dynamic and forward-looking company whose close partnerships with its customers enables it to provide intelligent, cutting-edge and cost-effective solutions in response to their most demanding operational requirements

XTEK Limited – Annual General Meeting

Strategic Development

Vision Achieved By:

- **More Effective and Responsive Structure**
- **More Effective Use of ICT**
- **Updated Product Lines and Capabilities**
- **More Effective Communication**
- **Reduced OPEX**
- **More Effective Use of Engineering Development Capability**

Strategic Development Revised Company Structure

ORGANISATION CHART - XTEK Ltd
XDOC1 - 241011

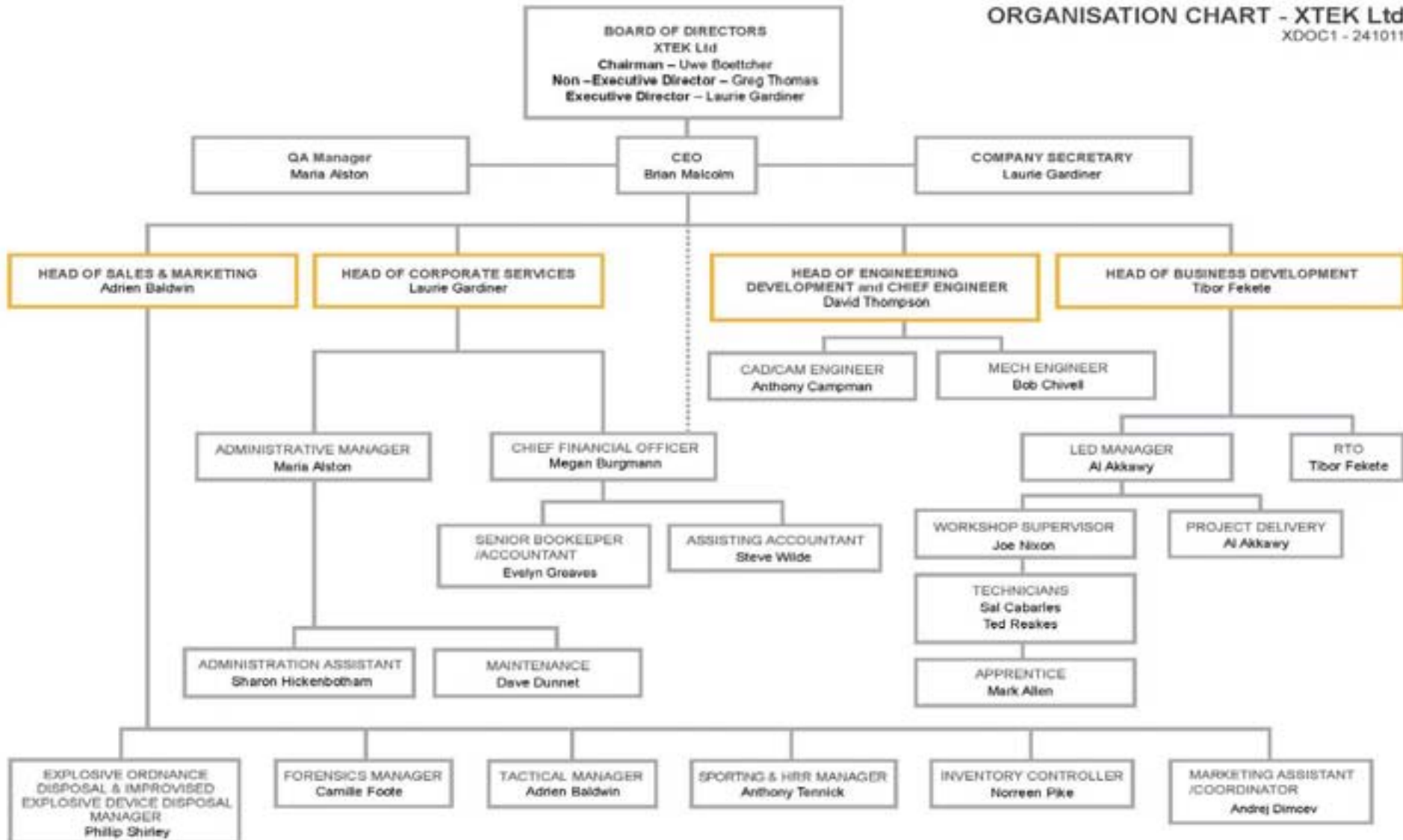

XTEK Limited – Annual General Meeting

Strategic Development

- **Structural Advantages**
 - **More Depth**
 - **Ability to Focus on Current and Future Operations**
 - **Dedicated Head of Sales**
 - **More Effective Executive Decision Making**

XTEK Limited – Annual General Meeting

Strategic Development

Vision Achieved By:

- More Effective and Responsive Structure
- **More Effective Use of ICT**
- Updated Product Lines and Capabilities
- More Effective Communication
- Reduced OPEX
- More Effective Use of Engineering Development Capability

XTEK Limited – Annual General Meeting

Strategic Development

- **More Effective Use of ICT**
 - **MYOB EXO**
 - 4 in 1
 - Inventory Management
 - Job Costing and Tracking
 - Predict Customer Requirements
 - Accurate Reporting and Forecasting
 - **Dealers-on-Line**

XTEK Limited – Annual General Meeting

Strategic Development

Vision Achieved By:

- More Effective and Responsive Structure
- More Effective Use of ICT
- **Updated Product Lines and Capabilities**
- More Effective Communication
- Reduced OPEX
- More Effective Use of Engineering Development Capability

XTEK Limited – Annual General Meeting

Strategic Development

- **Updated Product Lines and Capabilities**
 - **NIC Hook and Line Equipment**
 - **Specialist EOD Training and Equipment**
 - **Mesa Remotely Piloted Vehicles**
 - **Raptor Explosive Detection Wipes**
 - **Sheerspeed Forensics Tents**
 - **WA Forensics Consumables**

Strategic Development

NIC Hook and Line Equipment



Specialist EOD Training and Equipment



Mesa Remotely Piloted Vehicles

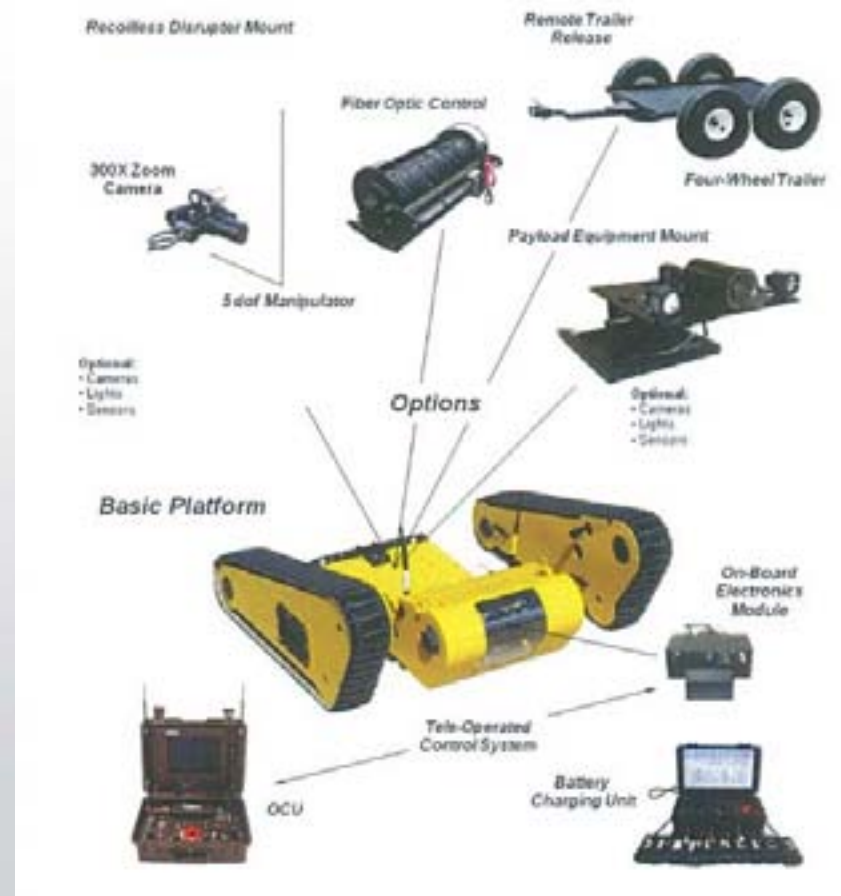

Strategic Development

Raptor Explosive Detection Wipes



Strategic Development

Sheerspeed Forensics Tents



Strategic Development WA Forensics Consumables



XTEK Limited – Annual General Meeting

Strategic Development

Vision Achieved By:

- More Effective and Responsive Structure
- More Effective Use of ICT
- Updated Product Lines and Capabilities
- **More Effective Communication**
- Reduced OPEX
- More Effective Use of Engineering Development Capability

XTEK Limited – Annual General Meeting

Strategic Development

- **More Effective Communication**
 - **External**
 - **Enhanced Website**
 - **Refined Marketing Strategy**
 - **Targeted Conferences and Demonstrations**
 - **More Regular Meetings with Customers**
 - **Improved ‘Reachback’ to US and UK**
 - **Internal**
 - **Weekly Coordination Meetings**
 - **Quarterly Sales Meetings**

XTEK Limited – Annual General Meeting

Strategic Development

Vision Achieved By:

- More Effective and Responsive Structure
- More Effective Use of ICT
- Updated Product Lines and Capabilities
- More Effective Communication
- **Reduced OPEX**
- More Effective Use of Engineering Development Capability

Reduced OPEX

Operational / Employee Expenditure (excluding depreciation and impairment costs)

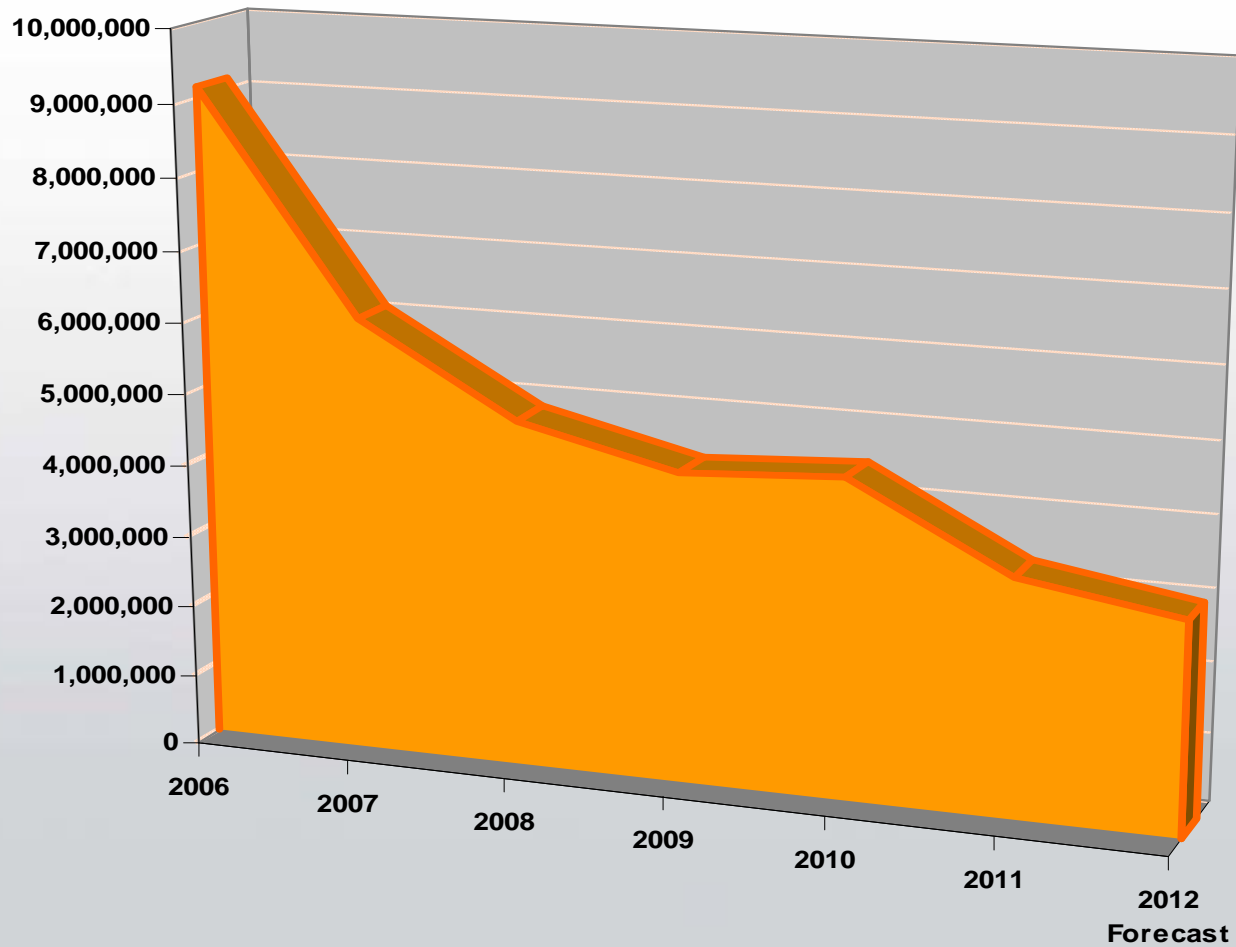

XTEK Limited – Annual General Meeting

Strategic Development

Vision Achieved By:

- More Effective and Responsive Structure
- More Effective Use of ICT
- Updated Product Lines and Capabilities
- More Effective Communication
- Reduced OPEX
- More Effective Use of Engineering Development Capability

XTEK Limited – Annual General Meeting

Strategic Development

- **More Effective Use of Engineering Development Capability**
 - **Increased Revenue from Company IP**
 - **Provision of Bespoke Solutions**
 - **More Effective Response to Technical Issues**
 - **Enhanced Corporate Brand**

XTEK Limited – Annual General Meeting

Strategic Development

ONE VISION – MANY SOLUTIONS

XTEK- One Vision

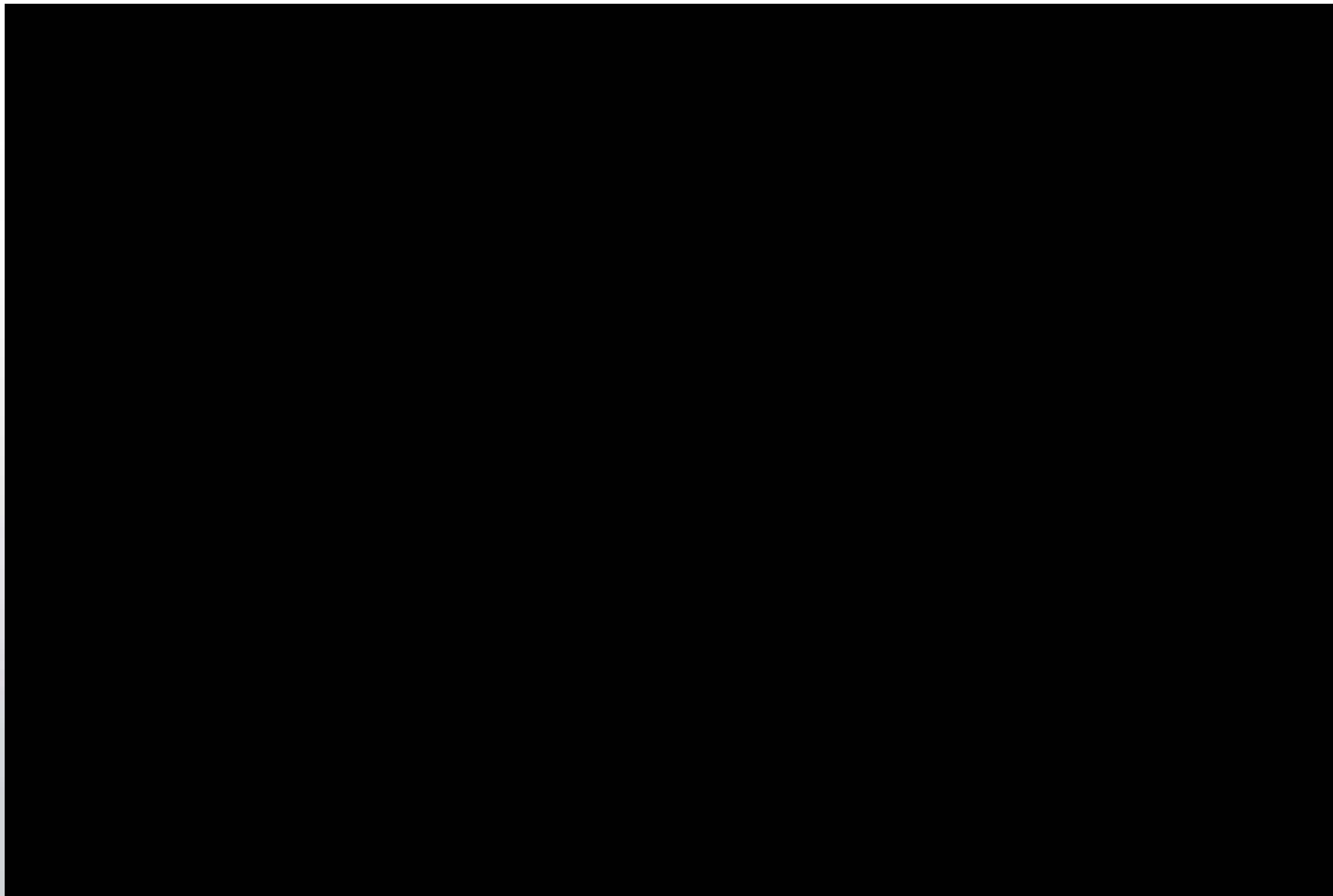

XTEK Limited – Annual General Meeting

Operational Focus

- **XTclave**
 - **Armour**
 - **Composite Manufacturing**
- **Unmanned Aerial Vehicles**
- **Precision Weapon Ancillaries**
- **Specialist Training**

- **XTclave Armour**

- **Joint Venture Agreement to be Signed Imminently**
- **First Production Plant Completed Early Next Year**
- **Discussions Continuing with Other Interested Parties**



XTEK Limited – Annual General Meeting

Operational Focus

- **XTclave**
 - **Armour**
 - **Composite Manufacturing**
- **Unmanned Aerial Vehicles**
- **Precision Weapon Ancillaries**
- **Specialist Training**

- **XTclave Composite Manufacturing**
 - Precision, Lightweight Carbon Composites Capable of Withstanding Extreme Thermal Loading
 - Investigating Armament, Aerospace and Aviation Industries

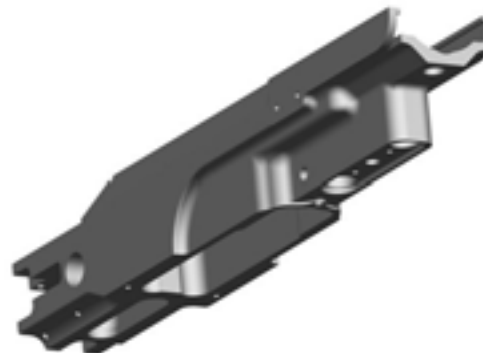

XTEK Limited – Annual General Meeting

Operational Focus

- XTclave
 - Armour
 - Composite Manufacturing
- **Unmanned Aerial Vehicles**
- Precision Weapon Ancillaries
- Specialist Training

- **Unmanned Aerial Vehicles**

- Represent AeroVironment – World Leader
- Contend for Defence JP 129 Phase 4



Raven



Puma



Wasp

XTEK Limited – Annual General Meeting

Operational Focus

- **XTclave**
 - **Armour**
 - **Composite Manufacturing**
- **Unmanned Aerial Vehicles**
- **Precision Weapon Ancillaries**
- **Specialist Training**

• Precision Weapon Ancillaries

- Developed Suppressor, Folding Chassis, Magazine and Sight Mount
- Suppressor Undergoing Trials with ADF
- Developing Portfolio for International Market

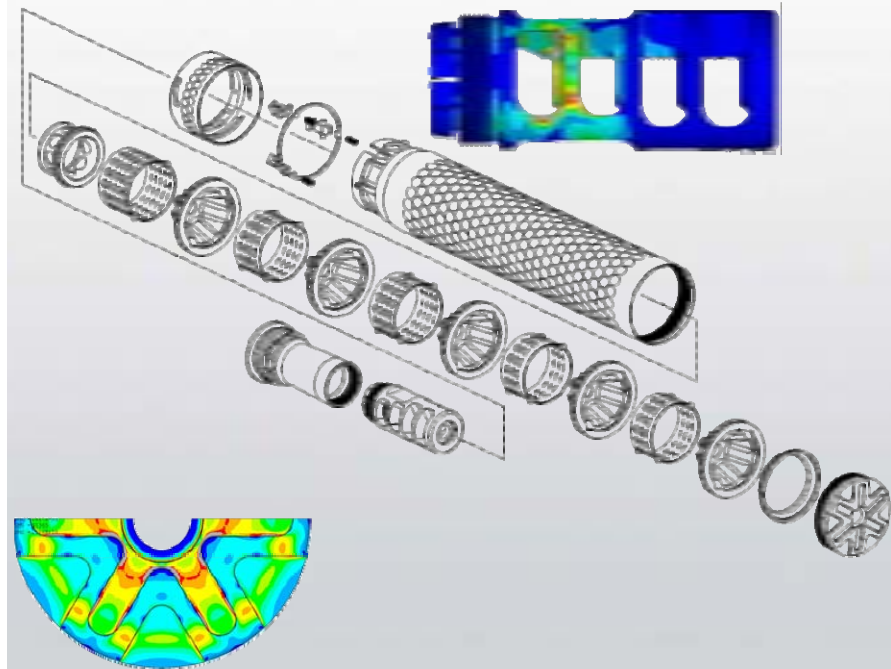

XTEK Limited – Annual General Meeting

Operational Focus

- **XTclave**
 - **Armour**
 - **Composite Manufacturing**
- **Unmanned Aerial Vehicles**
- **Precision Weapon Ancillaries**
- **Specialist Training**

- **Specialist Training**

- Registered Training Organisation
- Access to Specialist UK EOD Training Solutions
- Significant Market Potential



XTEK Limited – Annual General Meeting

Operational Objectives

- **Short Term Goals**
 - **Consolidation**
 - **Increase Agency Sales**
 - **Establish XTclave Joint Venture**
 - **Analyse Composite Manufacturing Capability**
 - **Develop Unmanned Aerial Vehicle Portfolio**
 - **Develop Precision Weapon Ancillary Suite and Establish Market in Australia**

XTEK Limited – Annual General Meeting

Operational Objectives

- **Medium Term Goals**
 - **Increase Agency Sales**
 - **Tiered Body Armour System**
 - **Develop Armour Manufacturing Capability**
 - **Develop Composite Manufacturing Joint Venture**
 - **JP 129 Phase 4**
 - **Establish Global Market for Precision Weapon Ancillary Suite**

XTEK Limited – Annual General Meeting

Operational Objectives

- **Long Term Goals**
 - **Establish XTclave in Global Armour Market**
 - **Establish XTclave in Global Composite Market**
 - **Develop XTclave and Investigate Further Markets**
 - **Establish XTEK as Company of Choice for Unmanned Aerial Vehicles in Oceania**
 - **Develop XTEK Engineering Development Capability**

XTEK Limited – Annual General Meeting

Conclusion

- **Company Driving Forward**
- **Identified the Need for Transformation**
- **Strategic Development Almost Complete**
- **Have the People, Strategy and Operational Focus to Succeed in Short Term and to Realise Considerable Medium and Long Term Potential**

XTEK Limited – Annual General Meeting

Questions